

# FIRE RATED ACCESSORIES

## Pyropanel PFS2003 Fire Seal

### DESCRIPTION

Pyropanel PFS2003 Fire Seal is an intumescent fire and smoke seal that is activated under fire conditions to restrict the passage of hot smoke and fire. The intumescent material softens and expands at high temperatures to seal the gap between the door edge and door frame to restrict the passage of hot smoke and help maintain the fire resistance level of the door.

### APPLICATIONS

Pyropanel Fire Seals can be rebated into the head and edges of either the door leaf or timber frame.

### FEATURES

- Creates a hot smoke seal to resist both fire and smoke under fire conditions
- Only 20mm wide X 2mm thick
- Can be used in conjunction with the Pyropanel *Life Safety door* range to upgrade the smoke resistance to Hot smoke
- Integrated PVC cover can be painted
- Can be rebated into either the door edge and head or into a fire rated timber door frame
- Available in Red (plastic coated) & Grey (uncoated)

### INSTALLATION

- Rebate 2mm x 20mm groove into timber door frame or edge of door leaf.
- Apply seal to rebate using integrated self-adhesive backing strip.
- Paint as required.

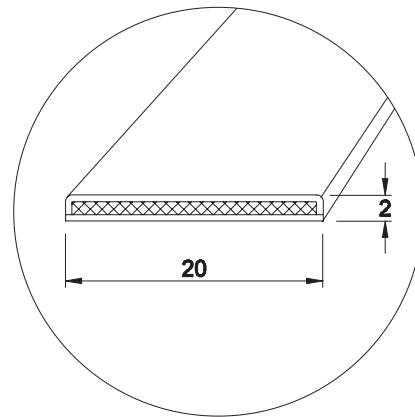

### SUITABILITY

All Pyropanel fire doors up to -/240/30

### MODELS AVAILABLE

Model	Colour	Overall size
PFS2003-R	Red	2mm x 20mm
PFS2003-G	Grey	2mm x 20mm

Pyropanel PFS2003 Fire Seal

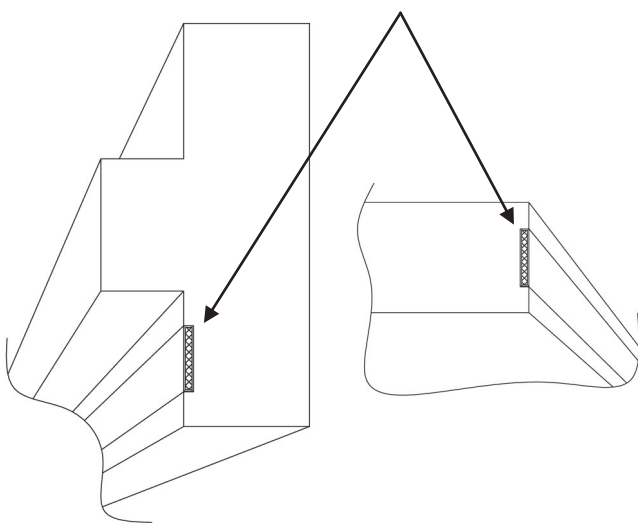

### HOW TO SPECIFY

"Install Pyropanel Intumescent Fire Seal PFS2003 to the head and sides of door frame / head and edges of door leaf\*"... etc,

\* Delete as required