

ASSA ABLOY

ACOUSTIC DOOR

1 hr fire rated, 50 Rw, Interconnecting Acoustic/Smoke/Fire door

DESCRIPTION

Pyropanel AS-INTERCON-A is an acoustic (50Rw), 1 hour fire rated interconnecting door leaf arrangement, consisting of a 47mm, 1 hour door and a 44mm special non-fire rated door in a single frame, both with approved perimeter seals and bottom seals.

APPLICATIONS

Ideal for interconnecting rooms that may require up to 1 hour of fire rating and an acoustic rating of 50 Rw.

FEATURES

Acoustic Rating

- 50 Rw

Fire Resistance

- /60/30

Smoke Resistance

- Meets the NCC requirement for a smoke door.

Door Configuration

- Two doors in a single frame. (Interconnecting)

Thickness

- 47mm (nom.) fire door, and
- 44mm (nom.) special non fire rated door.

Size

- Maximum Size - 2400mm high x 1200mm wide.

Frame

- Double rebated KDHW timber or Steel Euroseal door frame designed to receive one door on each side. The separation distance between the leaves is 80mm(min.)

Finish

- Ply/MDF faces to both doors as standard.

Seal combination:

Door Type	Perimeter	Bottom	Rw
AS-INTERCON-A	Euroseal	RP38si	50

OPTIONAL EXTRAS

- Pre-hung in steel or timber frame.
- Veneer or steel facings.
- Pyropanel Pyrodur 13mm thick Vision panels - 300 x 200 or 600 x 100mm. Glass rated to 38 Rw. Note - The inclusion of a vision panel will cause a slight reduction in acoustic rating.

INSTALLATION

Door frame must be tightly sealed against wall structure using Pyropanel Multiflex fire and acoustic sealant. Steel door frames require packing with fire rated plasterboard, Pyropanel M4 Mortar concrete or mortar to achieve the desired acoustic rating. Internal door hardware must be offset to prevent any clashing when both leaves are closed.

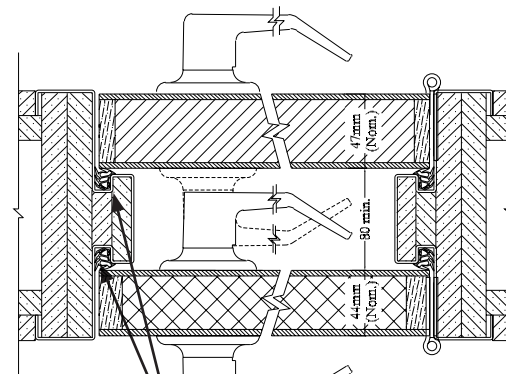

Pyropanel Euroseal

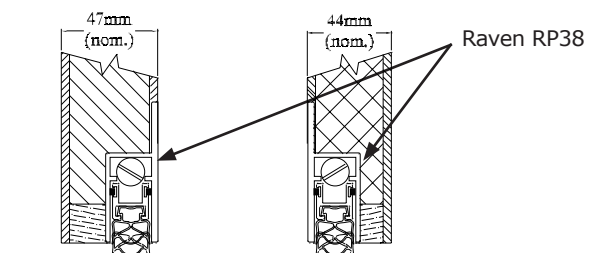

HOW TO SPECIFY

"Door to be a Pyropanel AS-INTERCON-A acoustic interconnecting doorset, installed into a Pyropanel fire-rated timber / packed steel* Euroseal door frame".

* denotes example - delete, change or specify as required

Pyropanel Developments Pty Ltd
 235 Huntingdale Rd, Oakleigh, Vic 3166
 Ph: (03) 9837 8500 Fax: (03) 9837 8550
 Email: sales@pyropanel.com.au
 Web: www.pyropanel.com.au



Distributed by:
Australian Commercial Doors
 P: (03) 9720 5766
 F: (03) 9720 5388
 E: sales@acdoors.com.au