

Description

ACD Metal Clad doors are fully metal clad door with an intergrated security lip, including a plastic coating over door for protection on site, including silconed top & bottom of door.

Applications

ACD Metal Clad units are designed for installations into factories, warehouses, public building's, shopping centres, showrooms and can be used as external pedestrian access doors.

Features

- Standard finish Zincaneal
- 3 Screw fixed heavy duty hinges with backing plates
- BCA compliant Lockwood 956/356 escape cylinder/ Lever as standard (other hardware available on request)
- Spring loaded holding chains
- Preformed security lip
- Plastic protective coating

Extra Overs

- Vision Panels
- Vent Grilles
- Door Closers
- Acoustic/Smoke Seals
- Euroseal Door Frame
- Stainless Steel/ Colorbond/ Galvanised finishes
- Refer to ACD frame profile sheets for entire range of standard frame profiles.
- Q-Sills
- Mortar Guards - for extra security

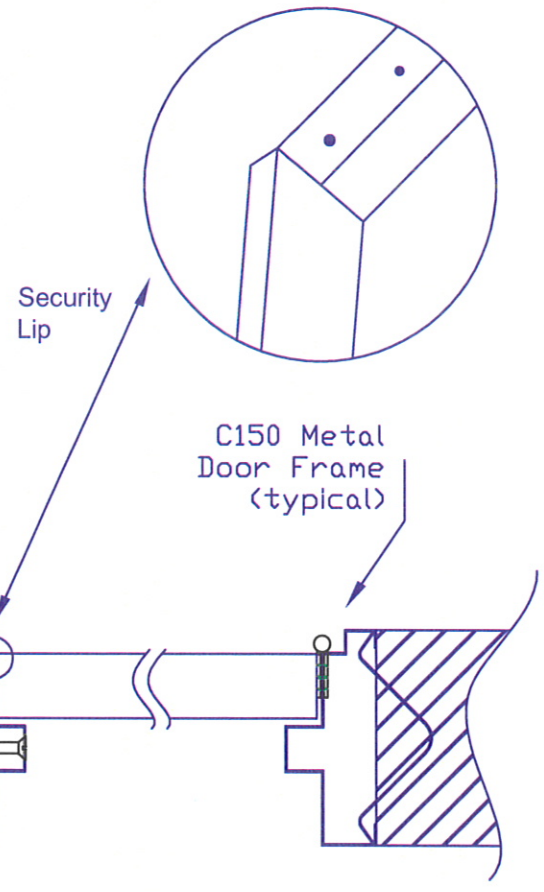
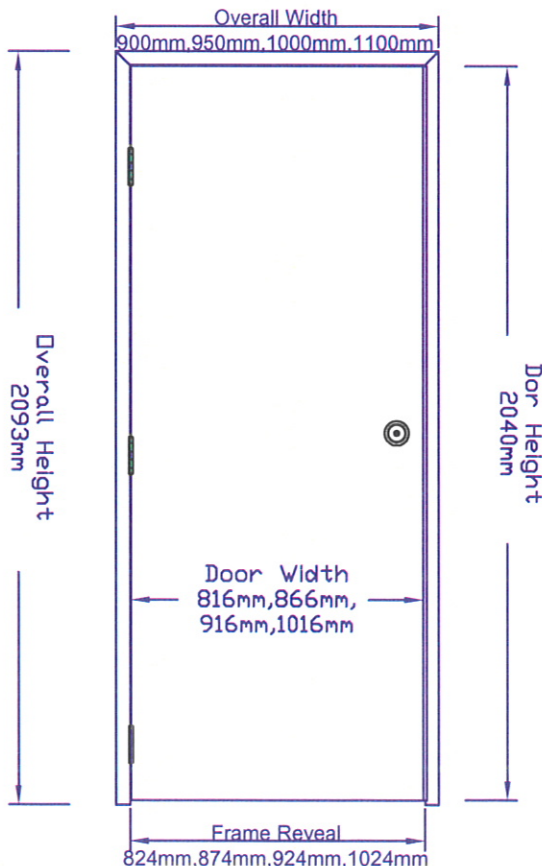

Sizes Available

Product Code	Door Size	Overall Frame Size
	2040 x 816 x 36	2093 x 900
	2040 x 866 x 36	2093 x 950
	2040 x 916 x 36	2093 x 1000
	2040 x 1016 x 36	2093 x 1100



Australian Commercial Doors

8-97 Bayfield Rd east, Bayswater
 Ph: (03) 9720 5766
 Fx: (03) 9720 5388
www.acdoors.com.au